

Wrapid Tape™

Primerless Crosslinked Protective Tape

Canusa-CPS is a leading manufacturer of specialty pipeline coatings which, for over 30 years, have been used for sealing and corrosion protection of pipeline joints and other substrates. Canusa high performance products are manufactured to the highest quality standards and are available in a number of configurations to accommodate your specific project applications.

Product Description

Canusa Wrapid Tape™ consists of a crosslinked polyolefin backing, coated with a protective, heat sensitive anti-corrosion adhesive which effectively bonds to steel substrates and common pipeline coatings including polyethylene and fusion bonded epoxy. Upon the application of heat, Wrapid Tape™ shrinks down to fully encapsulate the protected substrate. The product is packaged in convenient rolls with various widths to protect and repair pipelines, fittings, bends, elbows and other irregular configurations.

Features & Benefits

Easy Installation

The flexibility provided by the thinner tape dimension allows Wrapid Tape™ to effectively protect both conventional substrates such as circular pipe as well as irregular transitions such as elbows and risers. Upon the application of heat, the specially formulated adhesive flows into all surface irregularities, forming a protective barrier against corrosion.

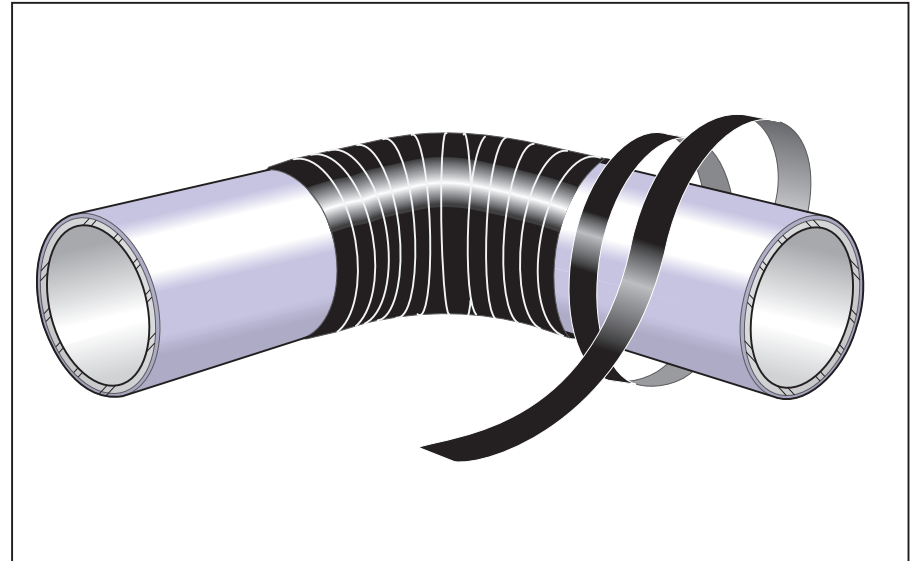

Saves Time & Money

Wrapid Tape™ is quick and easy to install. Since no special priming or operator equipment is required, product installation is quick and labour costs are kept to a minimum. Unlike conventional cold-applied tapes, Wrapid Tape™ does not require the use of high volatile primers, further minimizing costs and risks to health and safety.

Long Term Protection

Wrapid Tape™ is manufactured using materials that provide high electrical resistivity, low water absorption and low moisture permeability. The unique crosslinking process results in a protective backing that is much tougher than conventional tapes, more effectively resisting abrasion and damage, and thus extending the lifetime of the substrate. Wrapid Tape™ can also be double or triple wrapped for extra mechanical protection when required.

Applications



Oil & Gas



Water Pipelines



Repair & Rehab



Fittings

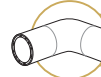

Bends

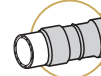

Girth-Weld Joints

Configurations



Wrapid Tape™



2-Layer

Pipe Sizes



All Sizes

Temperature Range



up to 55°C (131°F)

Wrapid Tape™

Operating Characteristics

Tape Operating Characteristics	Celsius		Fahrenheit		Hot Melt		Mastic	
					HCA	HCO	HCC	
Pipeline Operating Temperature	110°	230°						
	90°	194°						
	70°	158°						
	50°	120°						
	30°	85°						
Minimum Installation Temperature	-40°C (-40°F)							
Resistance to Soil Stress	60 (140) good				65 (149) good		60 (140) fair	
Main Line Coating Compatibility	PE, FBE, PU				Bit, CT, PU, PE, PP, FBE			

Tape Usage Guide

Nominal Pipe Diameter	Recommended Tape Width		Length of Tape Required				
	DN	inches	3D Bend		5D Bend		
25	1	50	2	2.8	9.3	2.8	9.3
40	1.5	50	2	4.0	13.2	4.6	15
50	2	50	2	5.2	17	6.2	20.3
80	3	50	2	8.5	28	10.6	34.7
100	4	50	2	12.3	40	14.8	48.6
125	5	75	3	11.1	36.4	13.6	44.6
150	6	75	3	14.3	46.9	18.3	60
200	8	100	4	16.3	53.4	20.8	68.2
250	10	100	4	23.1	75.8	30.6	100.4
300	12	100	4	30.4	99.8	40.9	134.2
>300	>12	150	6	see formula below			

The above table shows the typical usage for 3D and 5D bends, assuming a line coating cutback of 150 mm (6") and

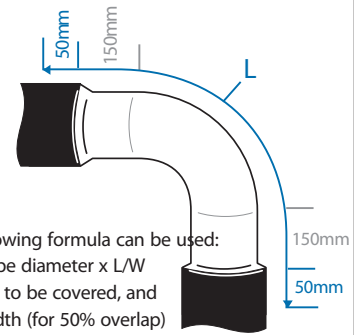

For other sizes, the following formula can be used:
 Length of tape = $\pi \times \text{pipe diameter} \times L/W$
 where L=length of area to be covered, and
 W= 1/2 of tape width (for 50% overlap)

Typical Product Properties

Adhesive	Test Standard	Unit	HCA	HCO	HCC
Softening Point	ASTM E28	°C (°F)	72 (162)	102 (216)	90 (194)
Lap Shear	ASTM D1002	N/cm ² (psi)	60 (87)	40 (58)	30 (44)
Backing					
Specific Gravity	ASTM D792		0.93	0.93	0.93
Tensile Strength	ASTM D638	MPa (psi)	20 (2900)	20 (2900)	20 (2900)
Elongation	ASTM D638	%	600	600	600
Hardness	ASTM D2240	Shore D	46	46	46
Abrasion Resistance	ASTM D1044	mg	45	45	45
Tape					
Impact	ASTM G14	pass/fail	pass	pass	pass
Peel	ASTM D1000	N/cm (pli)	35 (20)	52 (30)	26 (15)
Water Absorption	ASTM D570	%	0.05	0.05	0.05
Cathodic Disbondment	ASTM G8	mm rad	13	6	8
Dielectric Voltage Brkdwn.	ASTM D149	kV/mm	27	27	27
Low Temp. Flexibility	ASTM D2671C	°C (°F)	-32 (-25)	5 (23)	-14 (-7)
DIN Approval	DIN 30 672	class	C30/C50	-	-
Fully Recovered Thickness		mm (mils)	1.5 (60)	1.5 (60)	1.5 (60)

How To Order:

Dimensions & Ordering Info	HCA-B 75-15 BK		Wrapid Tape™	
	Colour		BK-Black, YE-Yellow	
Length of Roll		15m (50 ft)		
Width of Roll		50, 75, 100, 150, 200, 300 mm (2", 3", 4", 6", 8", 12")		
Bulk Roll Designation		B - Bulk Roll Designation		
Adhesive (thickness as supplied)		A - 0.75 mm (30 mils), O - 0.75 mm (30 mils), C - 0.75 mm (30 mils)		
Backing (thickness as supplied)		C - 0.4 mm (16 mils)		
Configuration		H - Tape		

The above represents standard ordering options. Consult your Canusa representative for any unique project requirements.

Speccoats Paint (Pty)Ltd • Speccoats Equipment (Pty)Ltd

Address: 9 Covora Street, Jet Park, Boksburg, Gauteng, South Africa

International Tel: 00 27 11 397 2140

Within South Africa Tel: 0861 37 2468

International Fax: 00 27 11 397 3420

Within South Africa Fax: 011 397 3420

Email: info@speccoats.co.za

Web: www.speccoats.co.za

